

* Optional: height can be reduced upon requirement. Details to be discussed.

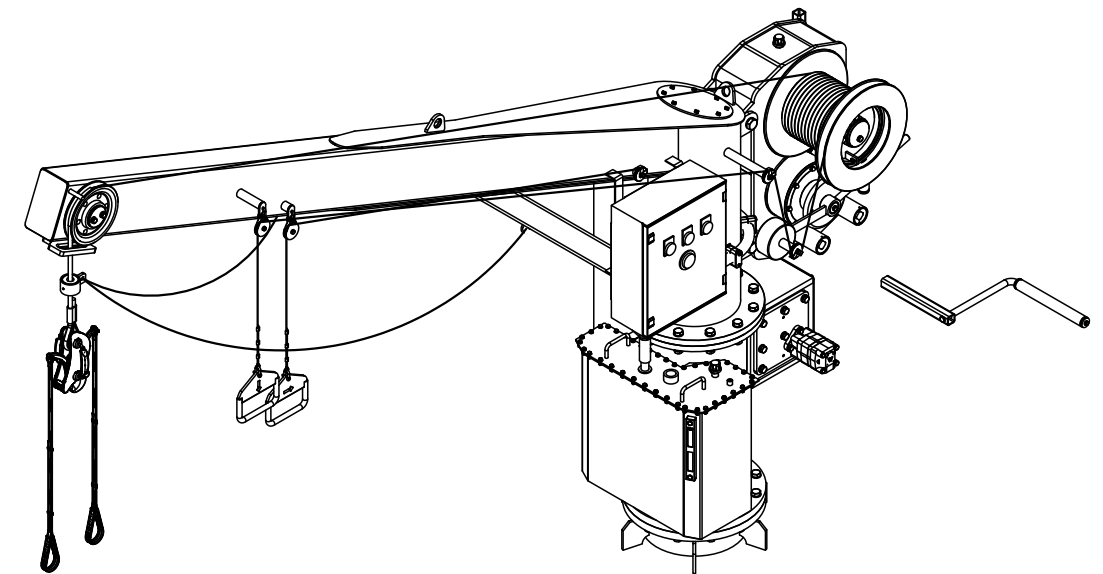
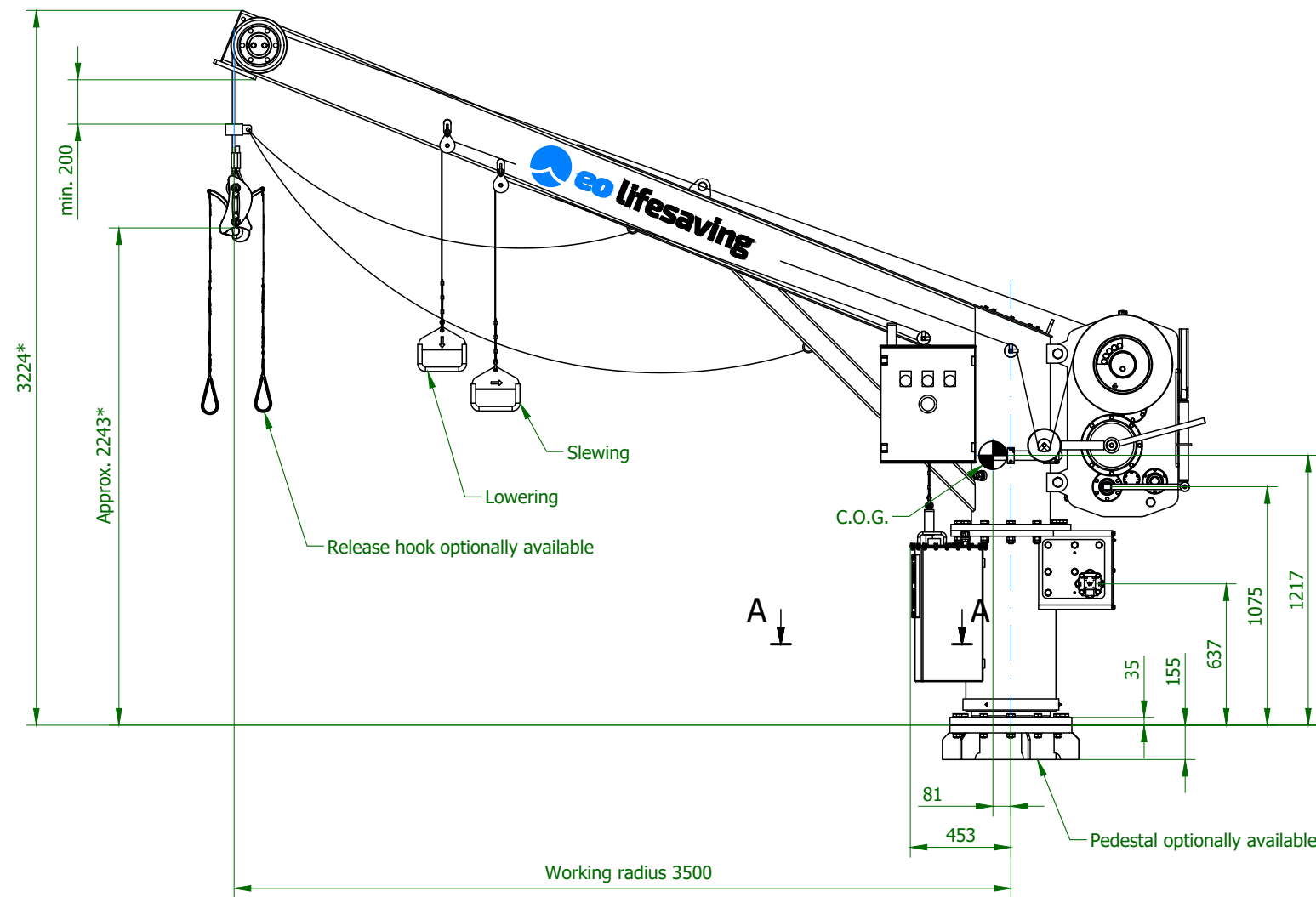

Recommended connection parts:

- Bolts M20x110, quality 10.9, DIN 6914 HDG Quantity: 12
- Nuts M20, quality 10, DIN 934 HDG Quantity: 12
- Washers M20, DIN 126 - 200HV HDG Quantity: 24

Tightening torque without lubrication = 580 Nm
Note: not lubricated

A-A (1:20)

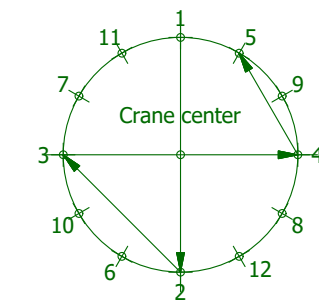
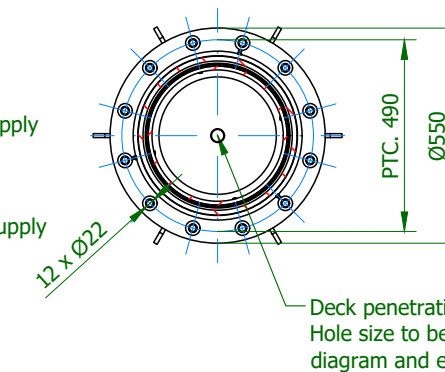

First 40%
Second 70%
Final 100%

Deck penetration for power supply cable.
Hole size to be determined in combination with electric diagram and electric cable requirements.

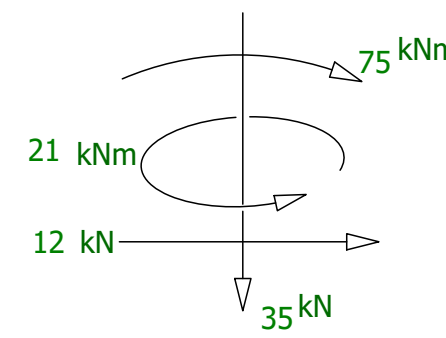
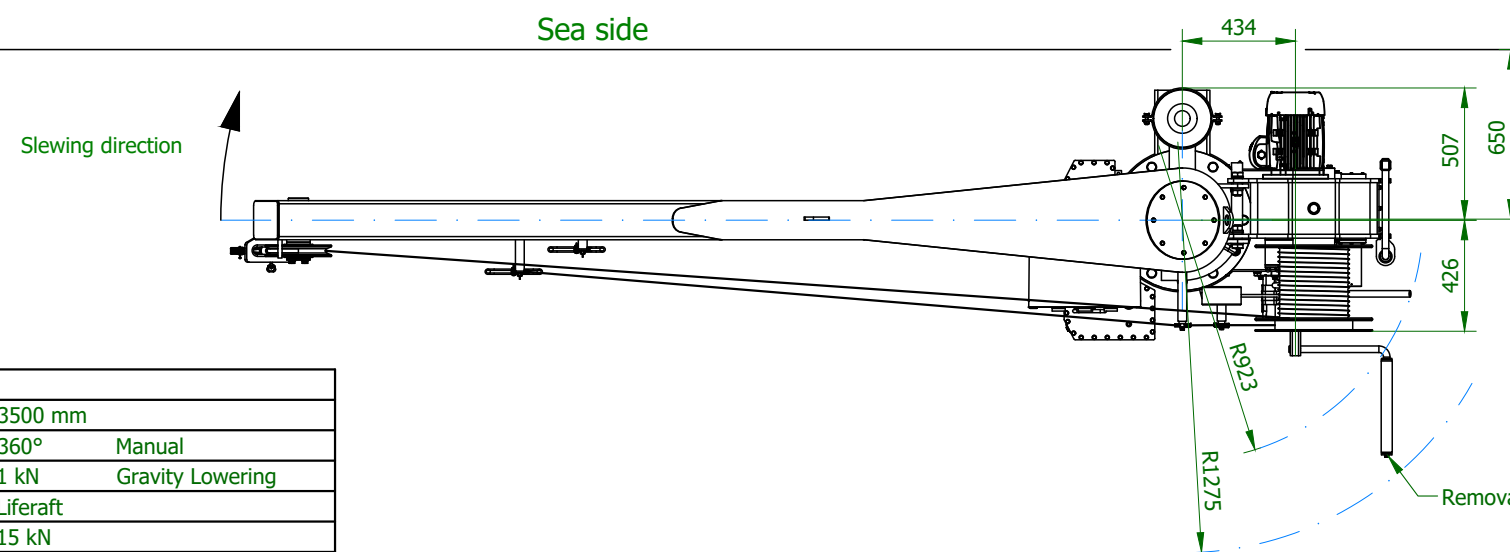

Right hand version has been drawn.
Left hand version is in opposite hand.

- Indicated forces are based on list and trim as mentioned in the SOLAS rules and regulation (20°/10° List and Trim).
- Forces are action forces and deck foundation should provide reaction strength.
- Deckforces including 10 % additional crane weight to compensate small fluctuations in system weight and position of COG.
- Indicated forces and moments are based SWL and above mentioned load situations.
- For deck structure integrity additional safety factors applicable for hull design should be applied.

General Data	
Working Radius:	3500 mm
Maximum slewing angle:	360° Manual
Minimum Working Load:	1 kN Gravity Lowering
Survival craft:	Liferaft
Safe Working Load (S.W.L.):	15 kN
Maximum Slewing Load:	10 kN
Maximum Hoisting Load:	15 kN Manually

Winch Data:		Wire rope data:	
Winch manufacturer:	Maritime Deck Machinery b.v.	Diameter:	14 mm
Winch type:	W-6116 M	Minimum Breaking Load:	188 kN, incl. pressed thimble
Winch drive:	Manual	Rotation-resistant:	multi strand, non-rotating
		Corrosion-resistant:	Galvanized, incl. pressed thimble

Total (dry) mass approx.: 1610 kg
(pedestal not included)

		Title: General arrangement & data for deck foundation CH-52 15/12-3.5 LR	
Creator: W.Watropa		Checked: L. Frac	
Approved: R. de Ridder		Date: 24.05.2017	
Size: A1	Scale: -	Units: mm	Projection:
Drawing Nr.: C3-0208		Revision: E	
Designed and manufactured by Maritime Deck Machinery		The reproduction, distribution and utilization of this document as well as the communication of its contents to others without express authorization is prohibited. Offenders will be held liable for the payment of damage. All rights reserved in the event of the grant of patent, utility model or design.	