

Seaside

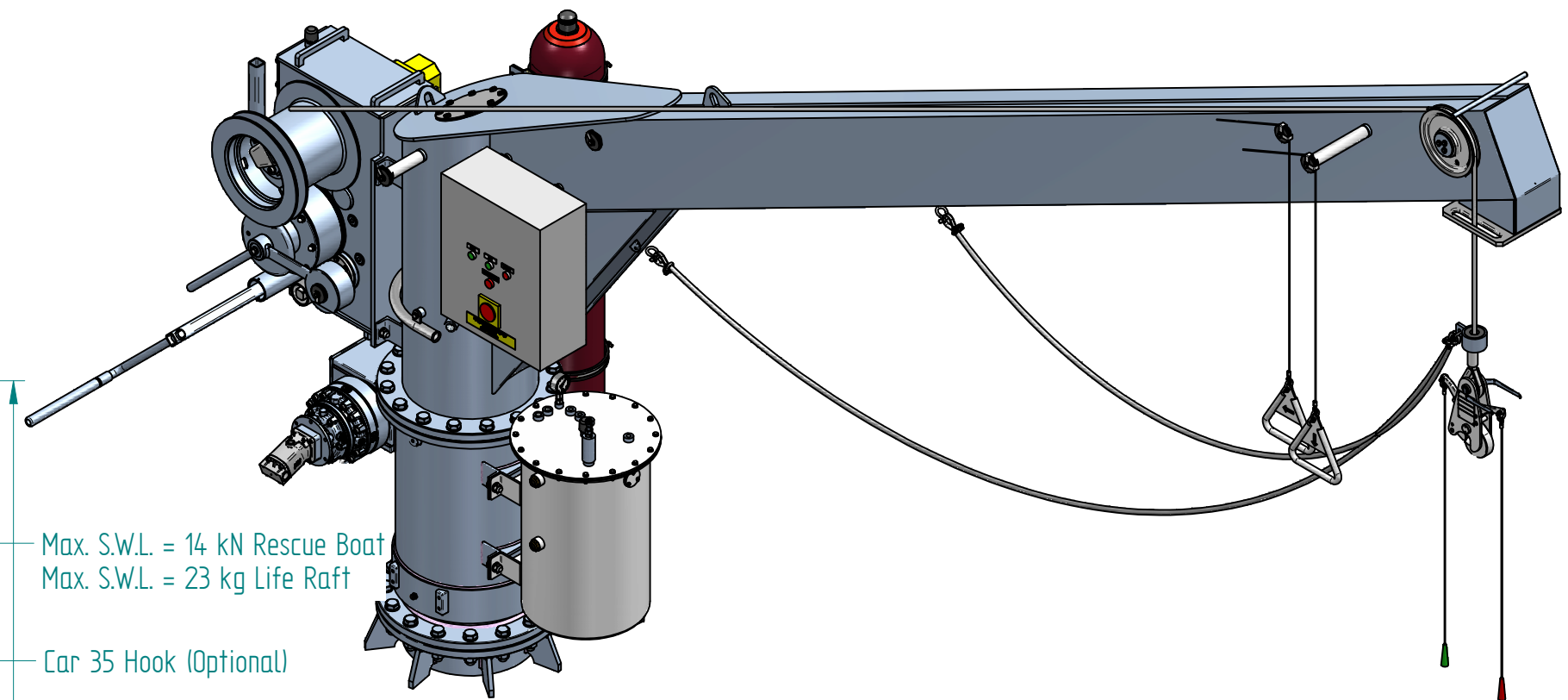
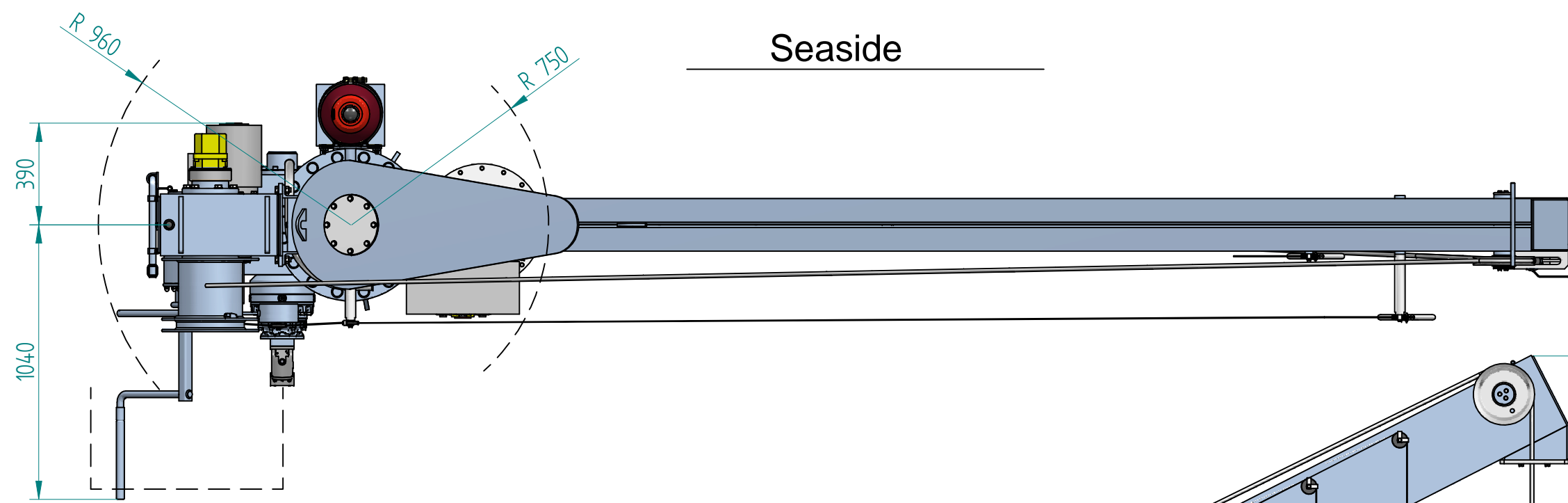

Max. S.W.L. = 14 kN Rescue Boat  
Max. S.W.L. = 23 kg Life Raft

Car 35 Hook (Optional)

Lifting hook and pedestal have to be ordered separately

Left-handed execution has been drawn  
Right-handed execution is in opposite hand

Lowering  
Slewing

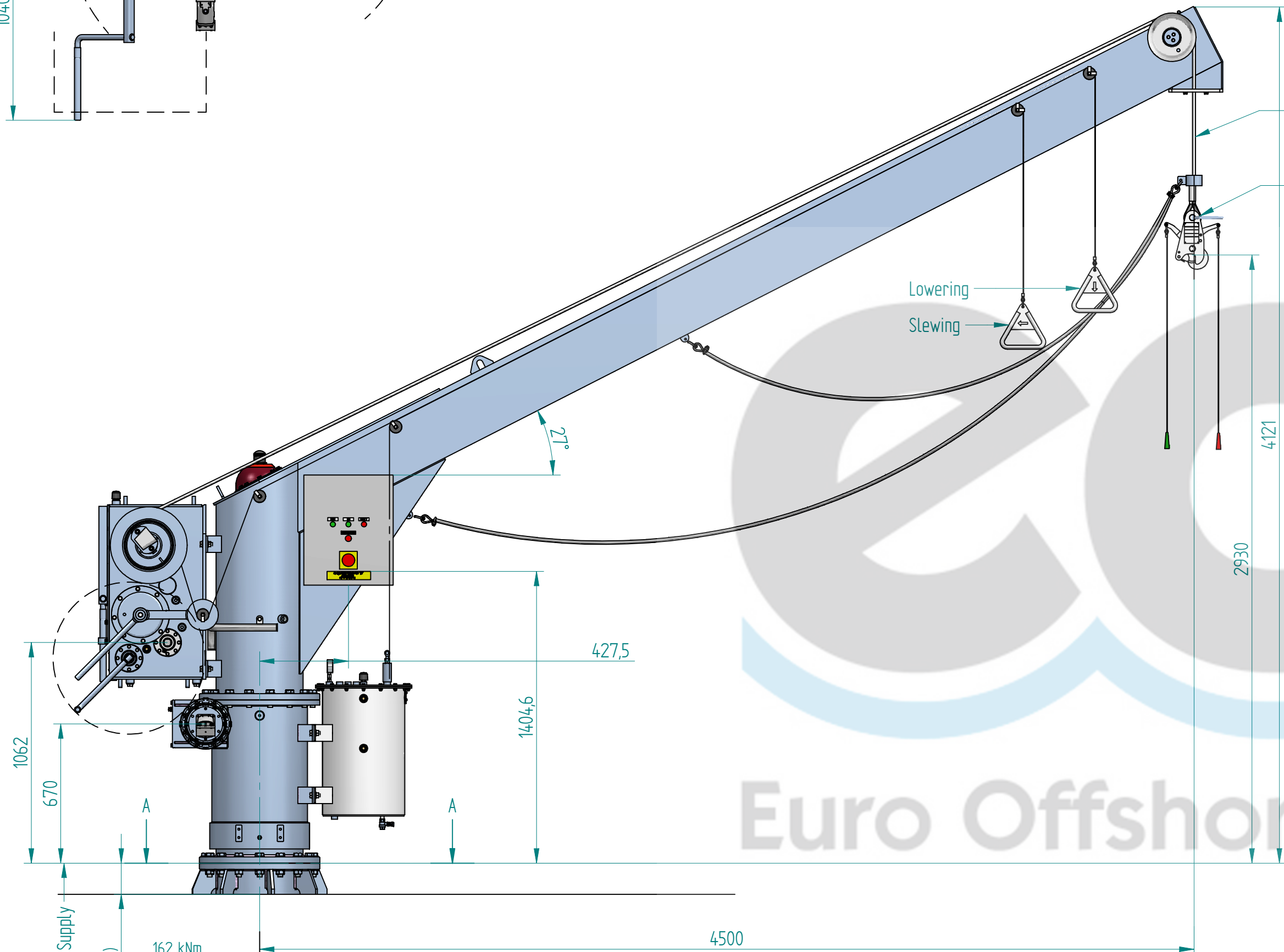

Execution of davit "RH" or "LH"

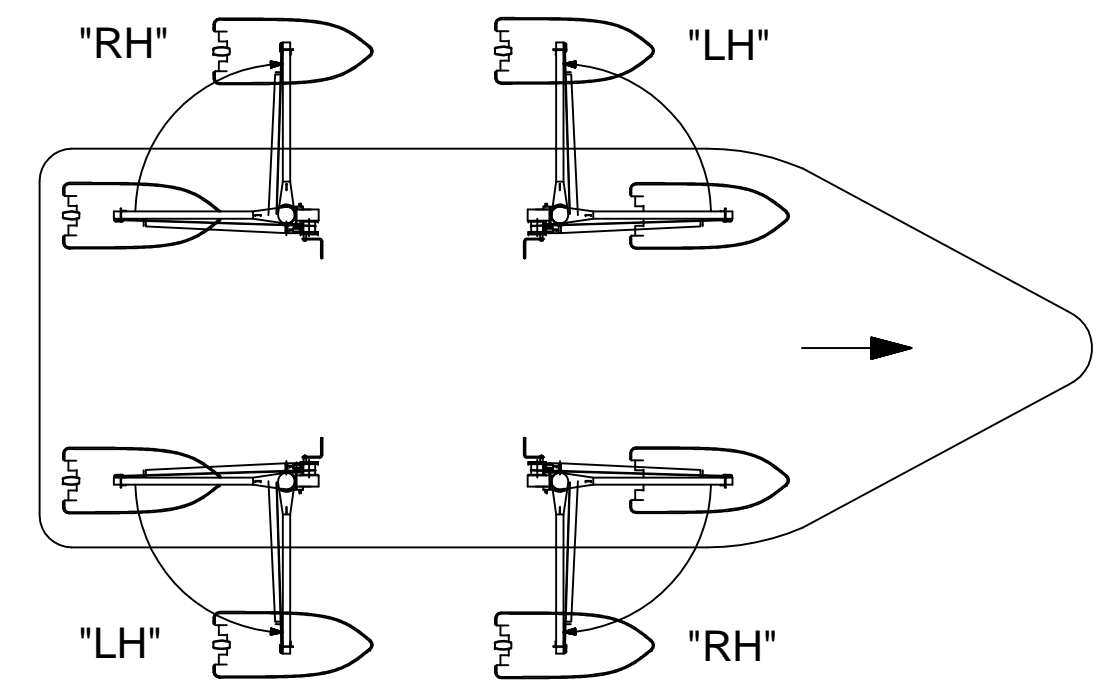

Euro Offshore.nl

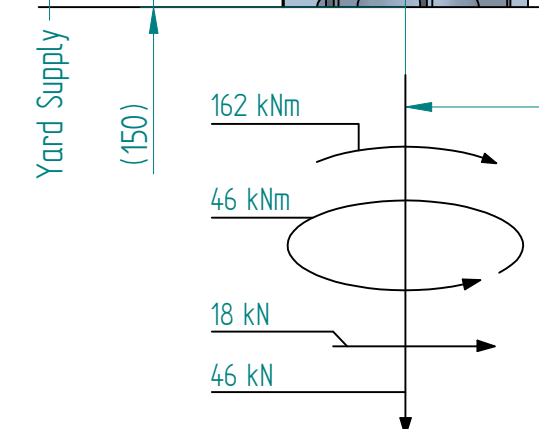

All forces are static calculated, taken under 10°/20° acc. SOLAS  
All forces are action forces on deck (section A-A).

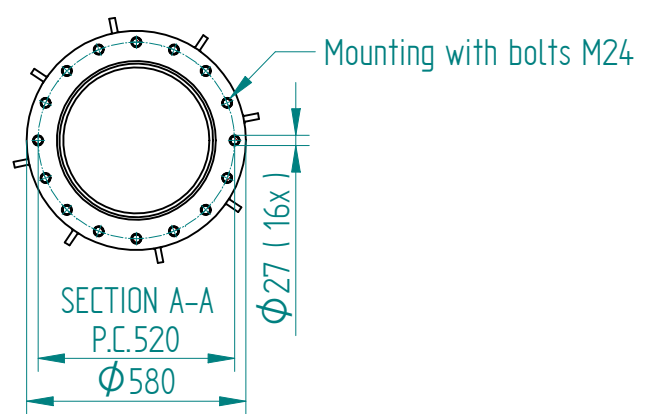

**Foundation Connection Parts**  
- 16 Bolts M24x100, Quality 10.9, DIN 931  
- 16 Nuts M24, Quality 10. DIN 934  
- 32 Washers M24 (200 HV), DIN 126  
Prespan Moment = 954 Nm

Total mass approx.: 2040.8 kg

Rev		RvB	GO	Name	TITLE: SCH 21/14-4.5 L/R LH
D	C	B	A	Rev Date Description	 Member of the Pallinger Group <b>NED-DECK MARINE</b> Survival Systems & Deck Equipment Ambachtsweg 10 3771 MG Barneveld Tel.: (31) 342-422105 Fax: (31) 342-492717 www.neddeckmarine.com
		20.3.12	bolt data		
		30.08.11	SWL update	GO	
This drawing is the property of NED-DECK MARINE B.V. The Netherlands It may not be copied or shown to any third parties					DRAWN.: GO DATE: 22-07-11 APPROVED: RvB SCALE: 1:20 DRAWING NUMBER: 3A-100676 TOLERANCES: NEN-ISO 2768-1 PROJECTION: SIZE: A2 REVISION: B
					File: 3A-100676B